



Dangerous Goods Safety Significant Incident Report No. 01-17 and Mines Safety Significant Incident Report No. 250

Unexpected initiation of detonator and detonating cord

Summary of incident

In August 2016, two shotfirers were attempting to initiate an open pit blast with a remote firing device (RFD). After two failed attempts, it was decided to manually fire the shot using a stomper (manual initiation device).

The shotfirers rolled out detonating cord from the blast site to the firing position on the waste dump, located outside the blast exclusion zone. A long-period delay detonator (LP detonator; 3.6 m lead, 9.6 sec) was connected to the stomper.

On the first attempt the stomper's shot-shell failed. On the second attempt the shot-shell fired, but when the detonator did not fire instantly one of the shotfirers thought the detonator had failed. The shotfirer cut the detonating cord below the detonator and picked up the detonator (and attached cord) to discard it. At this point the shotfirer realised it was a LP detonator and dropped it – a few seconds before it fired, initiating the attached detonating cord.

Without reporting the incident to the quarry manager, the blast crew proceeded to fire the shot manually after sunset, with a new LP detonator. Fortunately, there were no serious injuries or fatalities.

Direct causes

- Poor practice in the use of the manual initiation device (stomper) which was connected to a LP detonator rather than a lead-in line (signal tube) of sufficient length.
- The shotfirers were in a position where they were exposed to an explosives hazard (i.e. detonator and detonating cord initiating the shot).

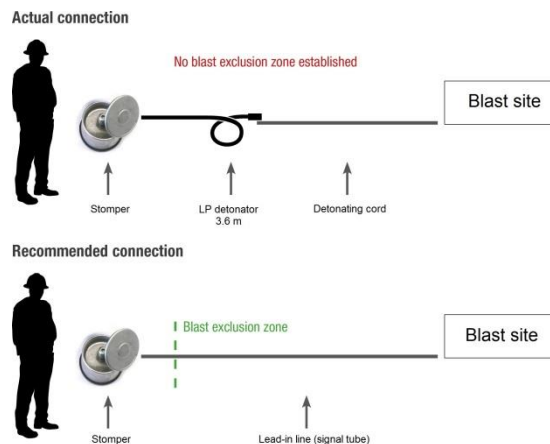

Actual and recommended hook-up of stomper

Contributory causes

Safe systems of work

- The formal risk management processes failed to identify deficiencies in risk controls for the use of explosives on site.
 - There was no procedure, formal training or assessment on the correct use and application of the stomper.
 - Inadequate supervision and monitoring practices contributed to the failure to identify a procedural gap in the use of the stomper.
- The risks associated with the change in work plan were not assessed using the site's task-based risk assessment tool.

Blasting practices and equipment

- LP detonators were not fit-for-purpose and were being used to run down excess stock.
- The blast plan design and document approval process was flawed (e.g. hook-up details were insufficient, hazards associated with use of LP detonators were not recognised).
- The primary initiation system for the shot failed.

Note: Problems with the remote firing device had been experienced in previous blasts. However, these were not rectified.

- The blast crew felt under pressure to fire the shot due to conditions (fading light, rising water levels) and to meet production requirements.

Actions required

Mining operators are reminded of the importance of identifying hazards associated with the use of explosives on site and developing safe systems of work to manage the risks. The following actions are recommended.

Safe systems of work

- As part of a risk assessment:
 - identify and consider all activities involving the use of explosives, including infrequent tasks and contingency plans
 - assess the adequacy and effectiveness of risk controls (considering the hierarchy of control) and monitor to ensure they are maintained.
- Develop and implement safe work procedures for blasting equipment and other blasting activities, based on the original equipment manufacturer's (OEM's) recommendations.
- Provide adequate training and assessment of competency for workers involved in blasting operations, including scenario testing for unplanned or unintended events.
- Management, supervisors and other knowledgeable persons should monitor and check actual work practices to confirm site procedures are followed.

- Conduct a task-based risk assessment when conditions and work practices change.

Blasting practices and equipment

- Use fit-for-purpose products in accordance with the OEM's recommendations.
- Clearly show planned tie-in and hook-up arrangements for blast designs and documentation, in accordance with site procedures and the Australian Standard AS 2187.2 *Explosives – Storage and use – Use of explosives* (Appendix A, section A2).
- Confirm designated firing times, provide adequate time to fire and conduct post-blast activities in daylight hours.
- Inspect and service equipment regularly in accordance with the OEM's instructions.
- Establish a system for the prompt reporting and rectification of defects in blasting equipment and accessories.

Incident reporting

- Confirm incident reporting standards (internal and external) are known by the workforce and followed.

Further information

- Standards Australia, www.standards.org.au
AS 2187.2 Explosives – Storage and use – Use of explosives
- Department of Mines and Petroleum
Mining safety publications, www.dmp.wa.gov.au/Safety/Mining-Safety-publications-16162.aspx
Explosives: Surface transport, use and disposal audit – guide and template
Accident and incident reporting – guideline
Dangerous goods safety publications, www.dmp.wa.gov.au/Safety/Dangerous-goods-safety-16164.aspx
Reporting dangerous goods incidents – guideline
What are blast plans? www.dmp.wa.gov.au/Dangerous-Goods/What-are-mining-blast-plans-4705.aspx
- Australian Explosives Industry and Safety Group (AEISG), www.aeisg.org.au
On-bench practices for open cut mines and quarries – code of practice
Blast guarding in an open cut mining environment – code of good practice

Ross Stidolph, Director Dangerous Goods and Petroleum Safety

08 February 2017